

CIRCLE SEAL CONTROLS

ATKOMATIC SOLENOID VALVES

INSTALLATION, MAINTENANCE, AND OPERATION INSTRUCTIONS

16000 SERIES Stainless, Normally Closed, Direct Lift

Installation Instructions

WARNING: These instructions should be read, understood, and followed before installation. Failure to do this can be extremely dangerous and cause valve malfunction.

1. An adequate filter system must be installed in the line ahead of each valve to prevent foreign matter from damaging the seal faces and/or obstructing the valve orifices causing operational failure and leakage. A maximum rating of such a filter is 40 microns to provide adequate protection.
2. Pipe thread sealing compounds and tape must be prevented from entering the valve.
3. New systems must be adequately flushed to remove all pipe scale, weld slag, thread burrs, etc. It is typically necessary to flush new systems several times, removing contamination lodged in filters and other components, until no debris is present.
4. Valves must be installed in a horizontal line with the coil oriented up (within +/- 10 degrees).
5. Mount the valve in the line such that the side port is the inlet (or the port marked "IN" on in-line valves) is the inlet and the bottom port is the outlet.
6. Check the nameplate and provide the specified voltage to the coil. Voltages must be as specified at the coil rather than the power supply. This is particularly important with DC applications due to their typically high voltage drop through supply lines. All AC coils are for single phase use only.
7. Coil housings may be rotated as required to match up with supply wiring. This is done by loosening the screw at the top center of the coil housing, rotating the coil housing assembly, and re-tightening the coil housing screw. Do not splice the lead wires inside the coil housing.
8. Use the valve only on the fluid, voltage, and pressure specified on the nameplate.

CAUTION: Valves should be handled carefully during installation with care taken to prevent damage to the cylinder cap tube inside the coil housing. Do Not tighten the valve in the line by applying pressure or torque to the coil housing. Use the wrench flats on either end of the valve body.

Note: On valves equipped with explosion proof coil housings it is necessary to use shims to Align the coil housing. A set of these shims is included with each valve with an explosion Proof housing. The part number for this shim kit is 61427 (Atko p/n 229). If the angular Alignment of the coil housing is not important the installation of the shims is not required.

Instructions for Installing Shims

- a. Unscrew the cast iron coil housing assembly from the valves bonnet or cylinder cap.
- b. Place the shims over the cylinder cap tube so they rest on the cylinder cap or bonnet.
- c. Screw the cast iron coil housing back onto the bonnet or cylinder cap.

Note: There are 4 shims with thickness of .005, .010, .015, and .020. Use any combination of these that allow the coil housing thread to bottom out such that the conduit fitting is oriented in the desired direction.

- d. Repeat steps b and c as required.

Note: Do not use more than .050 if shims (all those provided) or the explosion proof feature of the housing will be compromised.

The 16,000 series valves can be ordered and built with double wound coils for operation at high pressures. Valves with double wound coils are identified by the presence of a number 4 in the fifth digit of the model number (for instance, 16,004). Typically, valves with double wound coils are ordered with an Atkomatic time delay relay. The following diagram shows how these relays are wired:

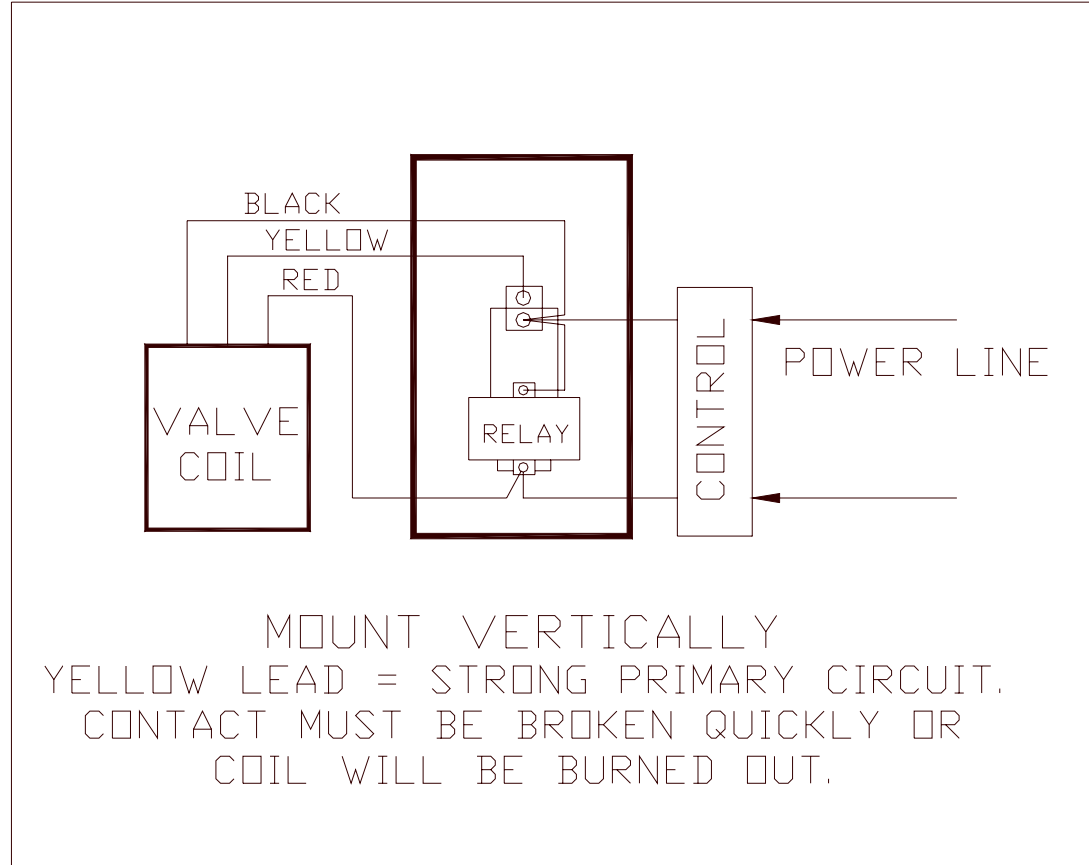

Maintenance Instructions

CAUTION: Only qualified maintenance personnel should work on the valve. If the valve is within the warranty period, do not disassemble without approval from the factory Returned Materials Department.

WARNING: Normal coil operating temperatures are high enough to cause severe burns – DO NOT TOUCH HOT COILS OR COIL HOUSING WITHOUT ADEQUATE PROTECTION.

Coil Replacement

WARNING: Turn off electrical power to the coil

1. Disconnect the coil's electrical leads.
2. Loosen the cap screw and remove the nameplate.
3. Remove the coil hold down spring, and the upper end plate.
4. Pull the coil and can assembly off of the cylinder cap tube.
5. Separate the coil from the coil can.
6. Remove the upper and lower end plates from the coil.
7. Replace the coil and reinstall the parts in their original order.

CAUTION: Do not apply voltage to the coil until it is installed in the completely assembled housing.

CAUTION: Be certain that all coil housing parts are reinstalled. Failure to install end plates, coil can, or hold down spring will result in coil burn-out.

Note: All coils, including AC and DC types, can be used interchangeably in the 16,000 series without changing any other parts. Operational pressures are lower with DC coils.

Cleaning or Replacement of Internal Parts

WARNING: Turn off electrical power to the coil and reduce the line pressure to 0 psi before beginning disassembly.

1. Remove the cap screw and lift the entire coil housing off of the body & cylinder cap.
2. Unscrew the cylinder cap from the valve body and lift it from the body. This will expose the plunger assembly which can be held with one hand while lifting the cylinder cap with the other hand.
3. Inspect all components.
4. Clean and replace components as required

CAUTION: When cleaning seat screw orifices, do not ream the out to larger diameters as prevent the valve from opening.

Warning: Inspect all o-rings. Worn o-rings should be replaced and all Teflon o-rings (white in color) should be replaced as they are not reusable. Failure to do this can result in external valve leakage and be extremely dangerous.

CAUTION: Attempting to take apart the plunger assembly is not recommended. The threaded parts are not re-usable and building the plunger assembly requires the use of special tools at the factory.

Note: Repair kits contain the complete plunger assembly.

Troubleshooting

1. Valves has trouble opening

- Is the fluid clean and free of contamination?
- Is the valve installed in the proper flow direction as indicated by “in” and “out” stamps?
- Is the voltage applied correct?
- Is the voltage within +/- 10% of the nominal?
- Is the voltage measured at the coil and with the valve energized? This is particularly important on DC applications.
- Is the ambient temperature above 104 F?
- Is there an audible click when the valve is energized? This indicates pilot operation. If no click is audible, check for contamination and/or bent or dented pilot tube.
- Is the fluid the same as that indicated on the nameplate?
- Has the pilot orifice become clogged with contaminates?

2. Valve has trouble closing

- Is the fluid clean and free of contamination?
- Is the valve being used for the same type of fluid for which it was built?
- Is the voltage within +/-10% of nominal?
- Is there a regulator or other flow restriction upstream of the valve?
- Is the valve actually not closing or closing very slowly or leaking excessively?
- Is there foreign matter lodged under the valve seat?
- Is the fluid more viscous than 150 SUS?
- Is there 100% back pressure (downstream piping shutoff) on the valve or does the downstream system pressure exceed the valve's inlet pressure?
- Has the valve stem become worn or damaged?
- Is the valve actually closing but leaking excessively?

3. Valve is leaking internally

- Is there any contamination in the fluid?
- How much is the leakage and at what pressure? If the leak is excessive it could be caused by a bent or dented pilot tube. If the leak is small, how does it compare with the factory leakage standard?
- Is the fluid chemically compatible with the seat material?
- Is the temperature of the fluid within the limits of the seat material?

4. Coil has burnt out

- Is the voltage applied correct?
- Is the voltage within +/- 10% of the nominal?
- Is the ambient temperature above 40 C (104 F)?

- Is adjacent equipment or piping radiating excessive heat to the valve or raising the air surrounding the coil above 104F?
- Is the fluid temperature above that for which the valve is rated?
- Is the valve's coil housing assembled correctly? Has the customer opened up the coil housing? Are the end plates installed and oriented correctly? Has the coil hold-down spring been reinstalled?
- Have the coil leads been cut or damaged in handling or installation?
- Is contamination or physical binding preventing the plunger from actuating? This will cause an AC coil to burn out. Monitoring the AC current draw and comparing the measured value to the holding current given in the catalog can check the presence of this condition.
- Is the cycle rate excessive (over once every 6 seconds for double wound coils)?
- Is the valve mounted in an enclosure that prevents free circulation of the ambient air?
- Was the coil failure immediate or did the burnout take hours or days? If immediate, the coil may have been defective or damaged and have shorted internally.

5. Valve leaks externally

- Has the valve been disassembled? The body o-rings are frequently Teflon and may require replacement to reseal.
- Is the bonnet nut or cylinder cap adequately torqued?
- Is the fluid chemically compatible with the seal material?
- Is the temperature of the fluid within the limits of the seat material?
-

6. Valve wears out quickly

- What is the cycle rate?
- Is the valve chattering or internal pilot stem & seat wearing rapidly (gas application)?
- Is the fluid contaminated with an abrasive material?
- Is the ambient or fluid temperature excessive?
- Is the fluid chemically compatible with the seal material?
- Is the temperature of the fluid within the limits of the seat material?
- What is the customer's definition of premature wear?

Contamination in fluid systems is the largest single cause of operational problems. Frequently contamination is present in new systems from sources such as pipe sealant, pipe scale, weld slag, and metallic particles from the assembly of pipe fittings. Flushing of new systems is important to reduce the occurrence of problems, however often even through flushing will not eliminate all contaminants that will break loose during the initial operation of a new system. Filters are an essential component in many systems to prevent valve problems. It is important to locate filters immediately upstream of the valves and to size the filter rating correctly. A maximum micron rating to provide adequate protection is 40 microns. Note that strainers or screens are generally not capable of providing this degree of filtration and a filter with a depth type of element is necessary.

Standard Available Coils

Single Wound Class H coils for 16000 Series Valves

<u>Voltage</u>	<u>Part Number</u>	<u>Resistance +/-10%</u>	<u>Inrush Amps</u>	<u>Holding Amps</u>	<u>Volt-Amps</u>
24 VAC 50 Hz	62175	1.25	4.80	2.5	115
24 VAC 60 Hz	62182	0.97	5.73	3.21	138
100 VAC 60 Hz	62171	18.72	1.25	0.60	125
110 VAC 50 Hz	62185	32.33	1.00	0.52	110
115 VAC 60 Hz	62212	23.07	1.14	0.58	131
200 VAC 60 Hz	62172	75.37	0.64	0.31	128
220 VAC 50 Hz	62189	126.4	0.50	0.27	110
230 VAC 60 Hz	62187	92.04	0.54	0.28	131
380 VAC 50 Hz	62177	379.3	0.27	0.14	124
460 VAC 60 Hz	62177	379.3	0.27	0.14	124
12 VDC	62174	4.17	2.94	2.11	35
24 VDC	62176	15.92	1.52	1.07	36
32 VDC	62185	32.33		0.98	31
72 VDC	62189	126.4		0.55	40
125 VDC	62178	485.9		0.24	30
250 VDC	62180	2212		0.11	28

Double Wound Class H coils for 16004 Series Valves

<u>Voltage</u>	<u>Part Number</u>	<u>Resistance +/-10%</u>	<u>Inrush Amps</u>	<u>Holding Amps</u>	<u>Volt-Amps</u>
100 VAC 60 Hz	63603	2.32 p 46.13 s	25.0	0.37	2500
110 VAC 50 Hz	62163	3.52 p 82.39 s	21.5	0.30	2365
115 VAC 60 Hz	62161	3.32 p 65.41 s	19.0	0.30	2185
200 VAC 60 Hz	63596	10.23 p 173.9 s	11.05	0.19	2210
220 VAC 50 Hz	62162	13.39 p 403.0 s	10.0	0.17	2200
230 VAC 60 Hz	62160	12.82 p 387.6 s	10.1	0.17	2323
460 VAC 60 Hz	62168	68.8 p 2710 s	3.7	0.058	1702
550 VAC 60 Hz	62159	73.8 p 3415 s	3.75	0.049	2063
24 VDC	62164	2.23 p 46.92 s	6.8	0.54	163
32 VDC	62164	2.23 p 46.92 s	6.8	0.54	163
48 VDC	62161	3.32 p 65.41 s	10.0	0.70	480
125 VDC	62166	8.65 p 461.7 s	14.0	0.24	1750
250 VDC	62168	68.8 p 2710 s	3.1	0.90	775

Double Wound Coils

The double wound coils consist of two coil windings within the same encapsulation. The windings are the primary, which consists of a heavy wire coil with relatively few turns and a low resistance and a secondary coil winding of many turns of fine wire with a high resistance. To open the valve, power is initially applied across the primary winding (red to yellow) and the combination of primary and secondary circuits in series (red to black) as shown schematically:

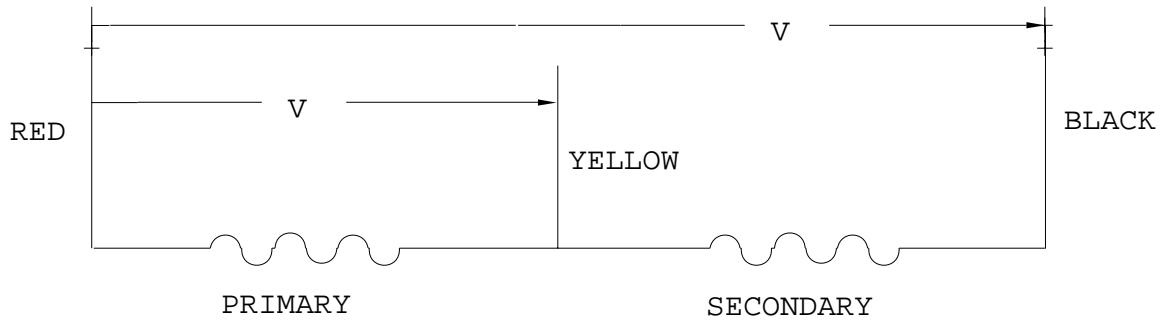

The high current through the primary circuit generates a strong magnetic field that actuates the valve. This current is sufficiently high that the coil would overheat if the current were allowed to continue for more than a couple of minutes. After a fraction of a second, (the delay is caused by the dropout time of the relay) the yellow lead is disconnected and the voltage remains applied only across the combination of the primary and secondary windings in series. The low current through both windings produces a lower strength magnetic field that is sufficient to hold the valve open. The low current produces only modest heating of the coil allowing the valve to remain actuated open continuously. This steady state condition is shown schematically:

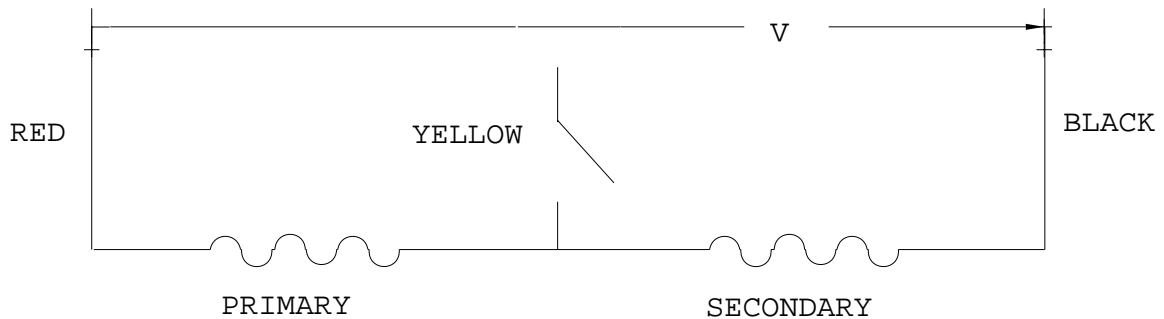

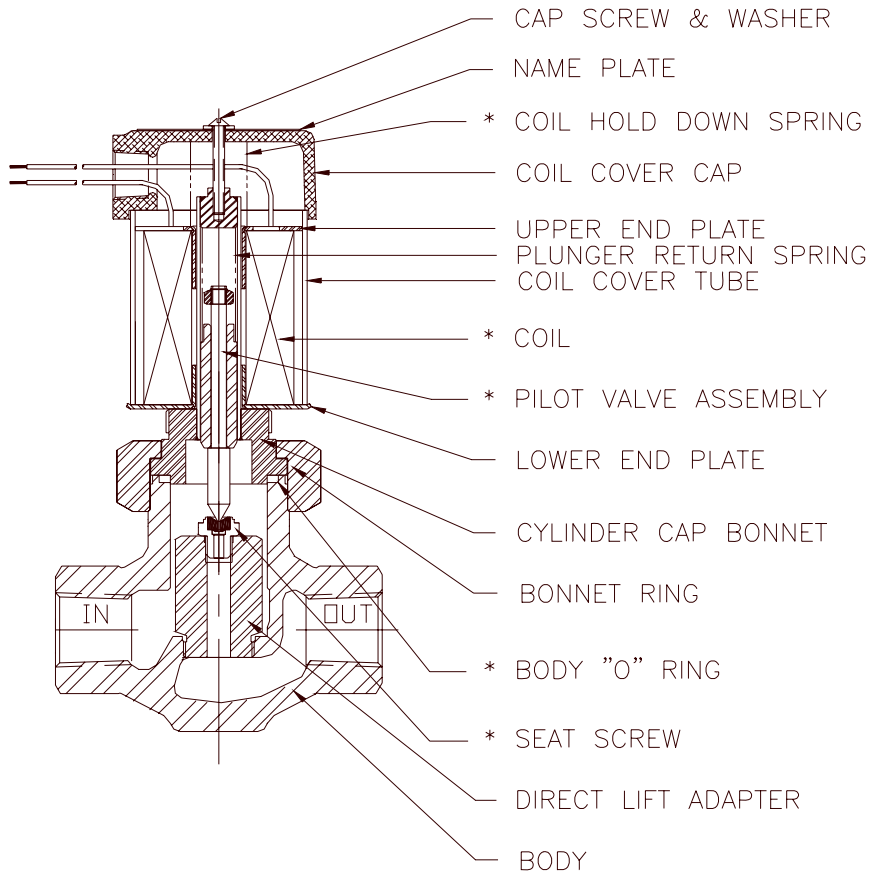

Shown is a Model 16200 1/2" Stainless Valve with a Standard NEMA 1 Coil Housing

Parts that comprise standard repair kits are identified in the cross section above. Repair kit numbers are the valve model number preceded by a K/. For instance the repair kit for a 16200-300P1AA1S valve is K/16200-300P1AA1S. All other valve parts are available for repair purposes. When ordering specify the parts desired by description the complete 14 digit catalog number. If the catalog number is unavailable, and specify: 1) the valve base model, 2) the pipe size, 3) fluid, 4) operational pressure (minimum and maximum), voltage and frequency, 5) temperature if different from ambient, and 6) any special requirements.

Dimensions, Shipping Weights, and Cv Flow Factors

16,000 Series Normally Closed, single and double wound coils

Catalog Number Prefix

<u>Single Wound Coil</u>	<u>Double Wound Coil</u>	<u>Pipe Size</u>	<u>X</u>	<u>Y</u>	<u>Z</u>	<u>Shipping Weight (lbs.)</u>
16000	16004	¼"	7"	6 1/8"	3"	6
16100	16104	3/8"	7"	6 1/8"	3"	6
16200	16204	½"	8 ½"	7 3/8"	4 5/8"	9
16300	16304	¾"	8 ½"	7 3/8"	4 5/8"	9
16400	16404	1"	9 3/16"	7 11/16"	5 ¼"	14

Cv Flow Factors

<u>Orifice</u>	<u>Cv</u>
1/16"	.093
3/32"	.22
1/8"	.44
3/16"	.72

Operation

Opening

When voltage is applied across the coil leads a current is produced in the coil windings which generates a magnetic field. The magnetic field attracts the plunger and causes it to move toward the center of the coil or magnetic stop. Initially the plunger slides freely on the stem until it impacts the nut or shoulder at the end of the stem. The plunger's momentum is then transferred to the stem and the stem is lifted off the seat screw or bottom nut orifice thus initiating flow through the valve.

Closing

When voltage is removed from the coil leads, the magnetic field collapses. Gravity pulls both the plunger and stem down until the stem point seals off the orifice stopping flow through the valve.

We manufacture a complete line of rugged dependable solenoid operated valves for pressure ranging from 0 to 10,000 psi.

Download a complete catalog of the Atkomatic Valve Product Line from <http://www.circle-seal.com/Atkomatic.html>

**Circle Seal Controls
Atkomatic Product
2301 Wardlow Cir.
Corona, CA 92880**