

# Catalog Options

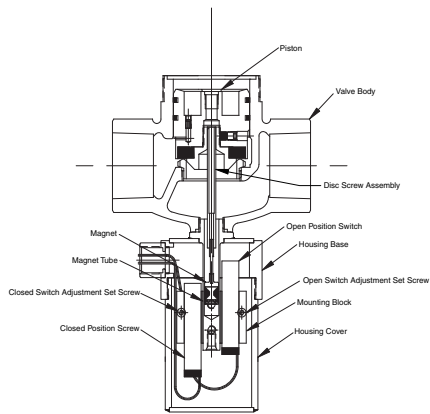

Valve position indicator option, shown with NEMA 7 explosion-proof housing

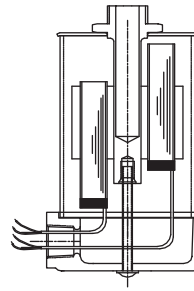

Valve position indicator option, shown with NEMA 1 standard housing

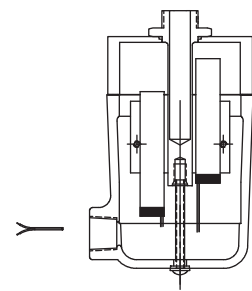

Valve position indicator option, shown with NEMA 4 waterproof housing

## Position indicator switches

This consists of a pair of reed switches that are mounted adjacent to a tube on the bottom of the valve. Inside of this tube is a magnet, which is physically attached to the piston so that it travels up and down with the piston motion. The reed switches are positioned such that when the valve is closed one switch is actuated closed by the magnet and the other switch is open. When the valve is fully open the other switch is actuated closed. It is not unusual for these switches to require some adjustments in position after final valve installation. There are set screws (one per switch) in the mounting block that can be loosened to adjust the switches position. The reed switches are a single pole, single throw configuration. Their maximum switching current is 0.7 amp for DC and 1.0 amp for AC. The maximum switching voltage is 150 volts on AC and 200 volts on DC. The switch contact rating is 70 watts on AC service and 50 watts on DC. The range of allowable fluid temperatures is reduced to a range from  $-320^{\circ}\text{F}$  to  $+450^{\circ}\text{F}$  ( $-196^{\circ}\text{C}$  to  $+232^{\circ}\text{C}$ ) when the position indicator option is installed on a valve. Typically position indicator switches are only ordered on semi-direct lift valves. It is possible to place them on pilot operated valves, but this is not generally recommended. This is because the piston position is dependent on the flow rate through the pilot operated valve. Since the magnet that actuates the switches is connected to the piston, variations in flow rate will cause the position switches to open or close. Additionally, final setting of the switches (which typically must be done after installation in the field) requires either full system flow through the valve or disassembly of the pilot operated valve and manual movement of the piston. The position indicator switch option is not available on direct lift valves.

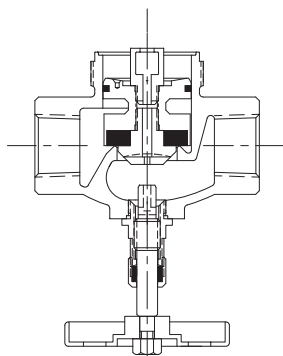

Manual opening device option

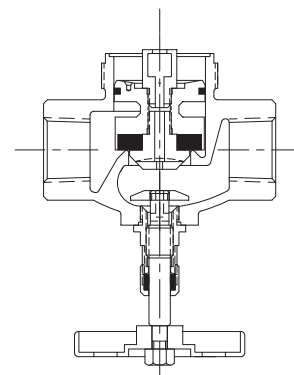

Manual throttling device option

## Manual opening

This provides a method for manually opening the valve typically for use when power failures occur. It consists of a hand wheel and rising stem attached to the bottom of the valve body. Turning the hand wheel causes the stem to mechanically push the piston open. This option requires the use of an anodized aluminum piston on models 31580 & 31590 which will affect compatibility with some fluids.

## Manual throttling

This provides a method of restricting the flow through a valve by reducing the area of the main valve orifice. It is physically similar to the manual opening device except instead of pushing the piston open, the stem pushes a baffle toward the main flow orifice under the piston. Quantitative metering of the flow is not a feature unless a separate instrument is used to measure the flow rate. This option requires the use of an anodized aluminum piston on models 31580 & 31590 which will affect compatibility with some fluids.

These options are coded into the standard catalog model number.

# Project Valve (Special, non-catalog) Options

This list of options includes some of the more commonly requested modifications to the standard catalog valves. Custom designs for specific applications are available for all the valve series. These can be requested from Circle Seal distributors or the Sales Department at Circle Seal. A complete list of stocking distributors for ATKOMATIC and other Circle Seal products is on the Internet at <http://www.circle-seal.com>.

- Flanges, pipe stubs, couplings, etc.: These are available in a variety of pressure ratings (Class 150, 300, 600, etc.) materials (stainless, carbon steel, etc.), and joining methods (butt welds, screwed and seal welded, socket welded, etc.). Special connections and installation of customer-furnished fittings is also available. Flange types available include raised face, flat face, slip-on, socket weld, weld neck, etc.
- Clad plunger for use with extremely corrosive fluids: A clad plunger consists of a slug of core iron which is encased in 316 stainless steel such that the magnetic material is separated from, and only the 316 stainless steel is in contact with, the fluid media. This option reduces operating pressure by 50% and is available on the 1000, 2000, 8000, 15800, and 16000 Series.
- Special sealing materials such as Kalrez®.
- Reduced internal leakage (frequently specified on 40000 and 50000 Series metal to metal seats accomplished by lapping seats).
- Stainless steel housings. These can meet NEMA 4X and Class I Div I Group B requirements.
- Check valve feature in piston assembly which allows full flow in the reverse direction: This consists of a small check valve mounted in the piston under the pilot orifice. There is no effect on normal valve operation, but the check valve closes off the pilot orifice when the valve is exposed to a reverse pressure differential. When this occurs the cavity above the piston is prevented from being pressurized by the downstream fluid. This allows the piston to be pushed fully open allowing free flow in the reverse direction. This option is not necessary on direct lift valves (they flow freely in the reverse direction) and is available on the following fully ported valve series: 500, 4000, 5000, 6000, 8000, 15400, 15800, 30400, 30800, and 40000. See the section on directional flow in the "Installation and General Information" section on pages 88–89.
- Fatigue resistant plunger assembly for high cycle applications: This consists of a sleeve that is brazed to the stem assembly replacing the threaded stem/nut connection.
- Nickel plating internal and/or external parts on bronze valves.
- Epoxy potted coil housings for under water installation.
- Carbon piston rings and/or metal o-rings where Teflon® material is not suitable (some radioactive environments).
- Extra length coil leads and/or ground wires for coil housings.
- Special threaded connections such as AND, MS, or SAE. Not all sizes available.

These and other non-catalog options cannot be coded into standard catalog model numbers. A project valve number is assigned by the Circle Seal factory to each valve having these or other special options. These project numbers consist of the catalog valve number prefix followed by a sequentially assigned dash number. An example project number is 31840–1529 which is a 1" stainless steel 31840 valve that has been modified to meet a specific customer requirement. The factory maintains a database of all previously built project or special valves produced. Consult the Sales Department at (951) 270-6200 for application information, numbering, pricing, and deliveries of all new and existing ATKOMATIC project valves.

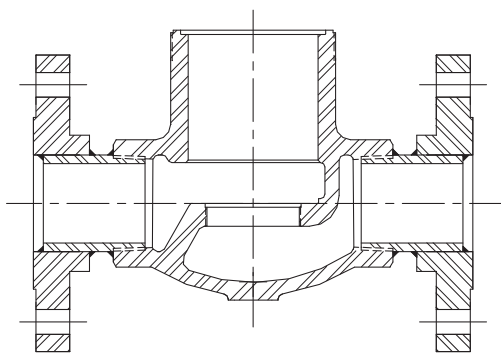

Example of coupling connection option

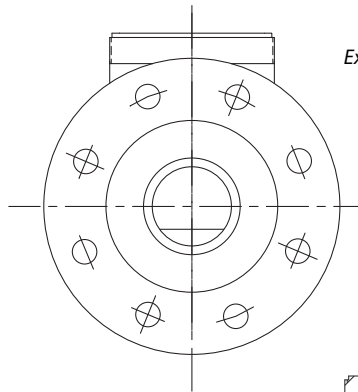

Example of flange connection option;  
raised face slip on flanges shown

